

# **Industrial Carbon Composites**

## **Data Flow Diagrams**

Sean Beebe

Cassie Fults

Curt Ireton

Chris Robinson

Adrian Wright

# Context Diagram

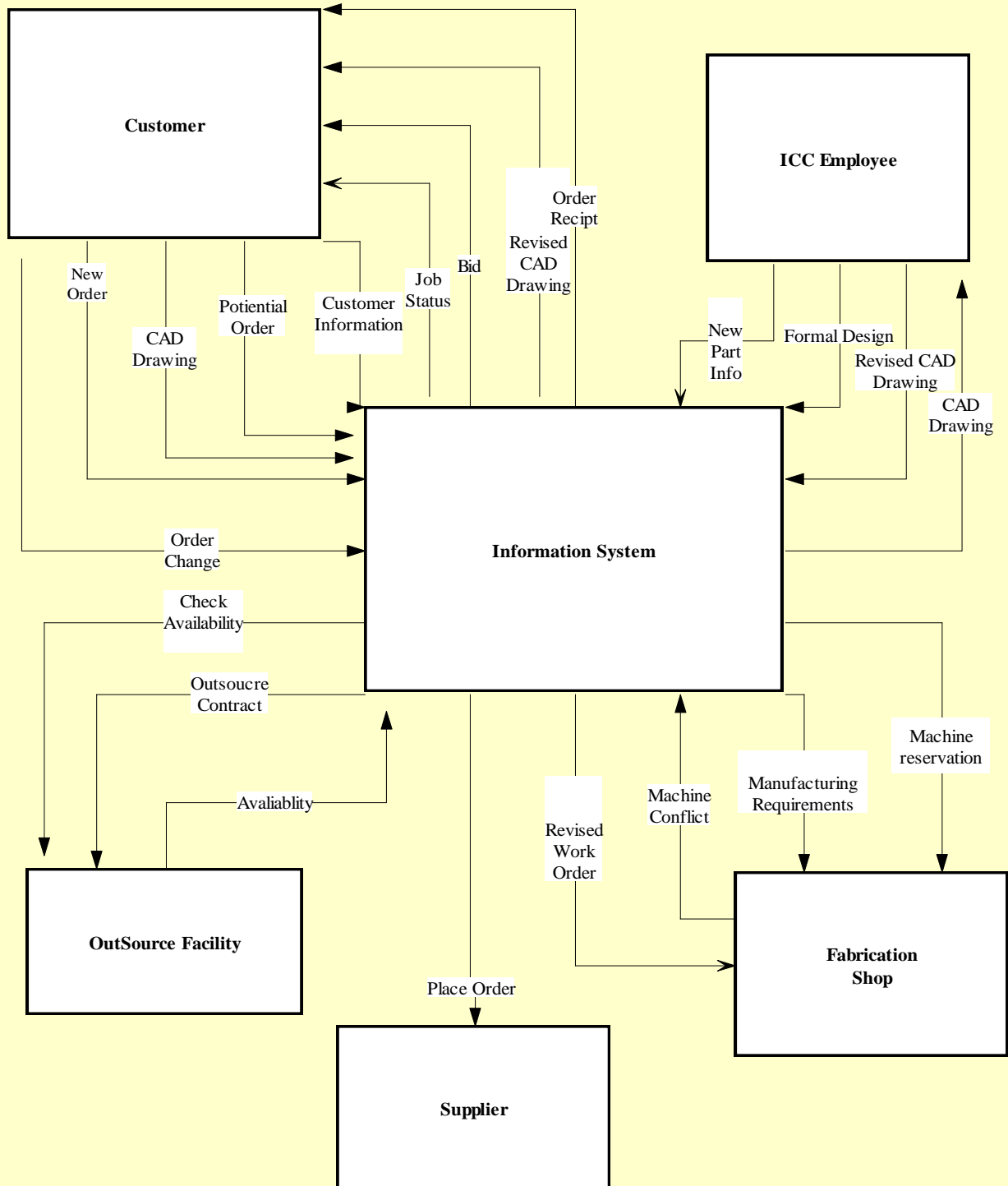

# Level 0 Diagram

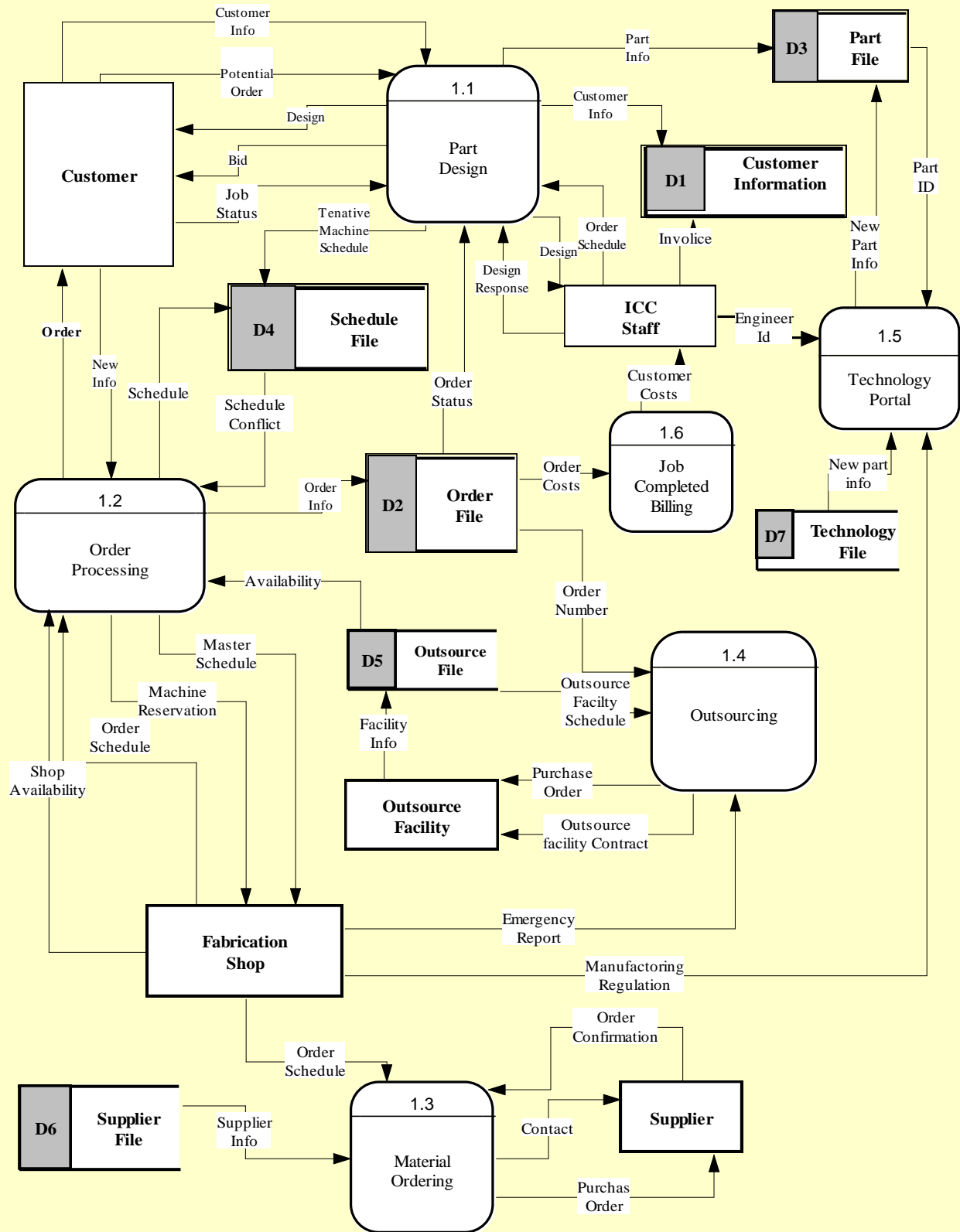

# Level 1 DFD for 1.1 Part Design

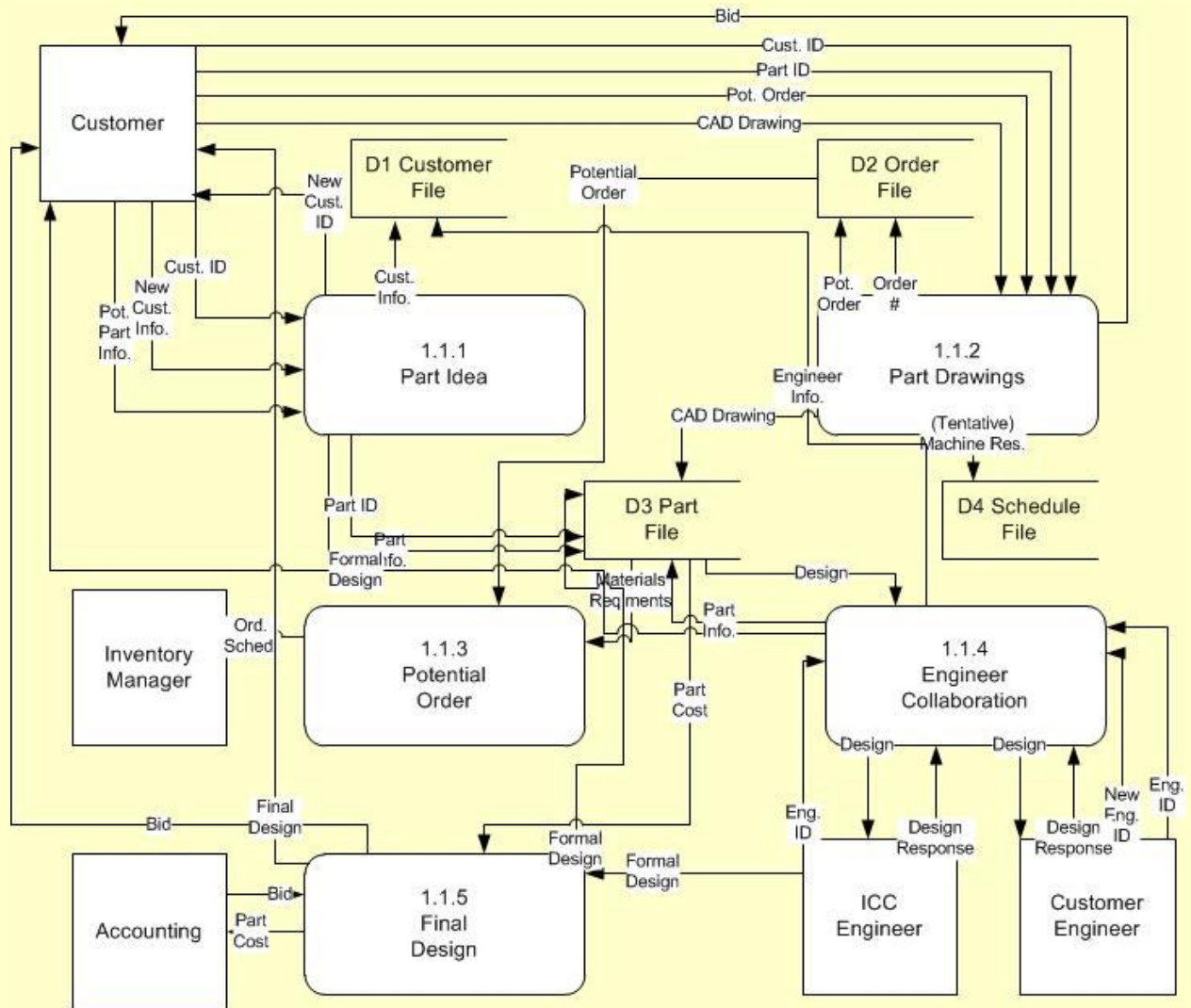

# Level 1 DFD for 1.2 Order Processing

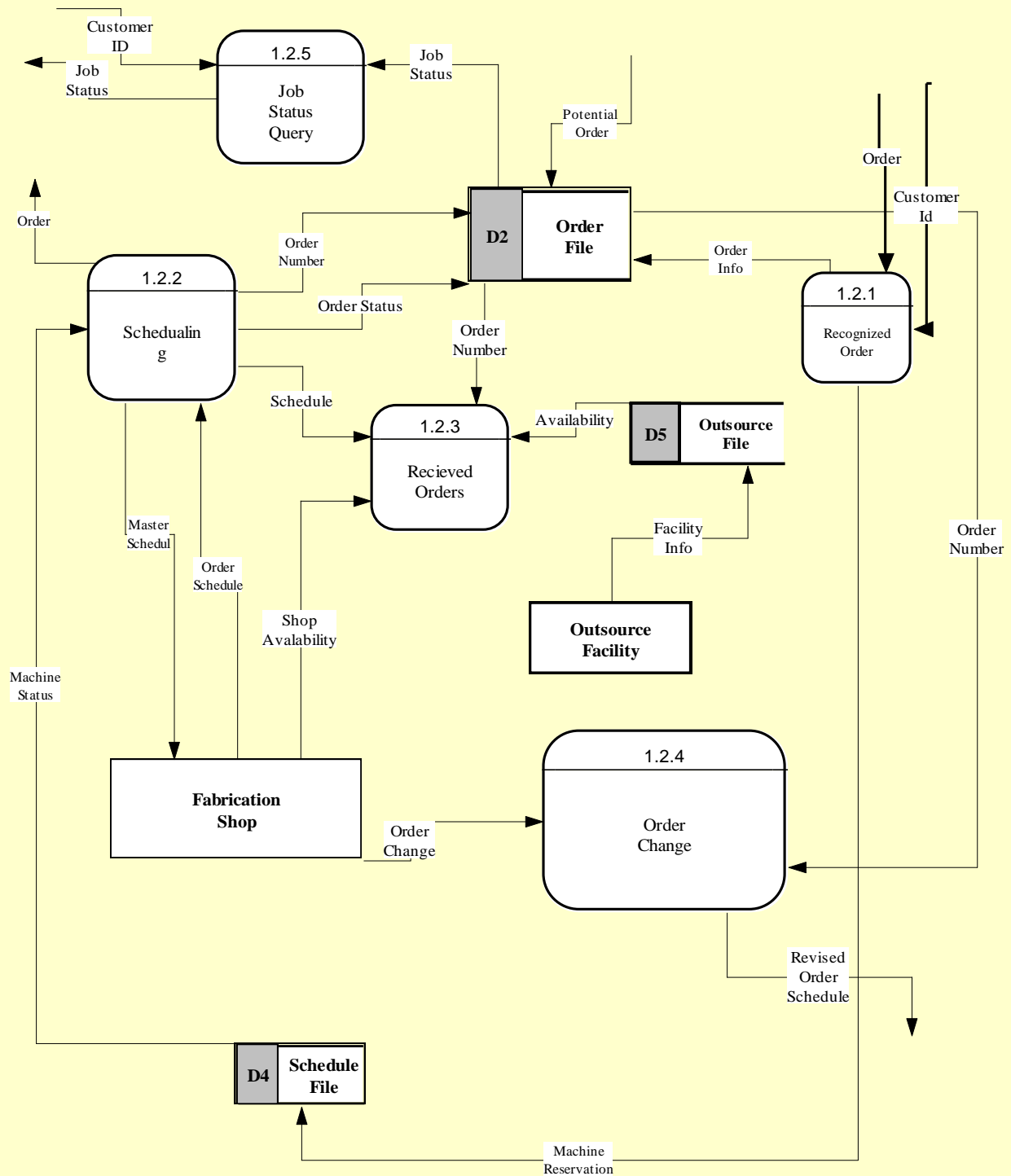

# Level 1 DFD Diagram for 1.3 Material Ordering

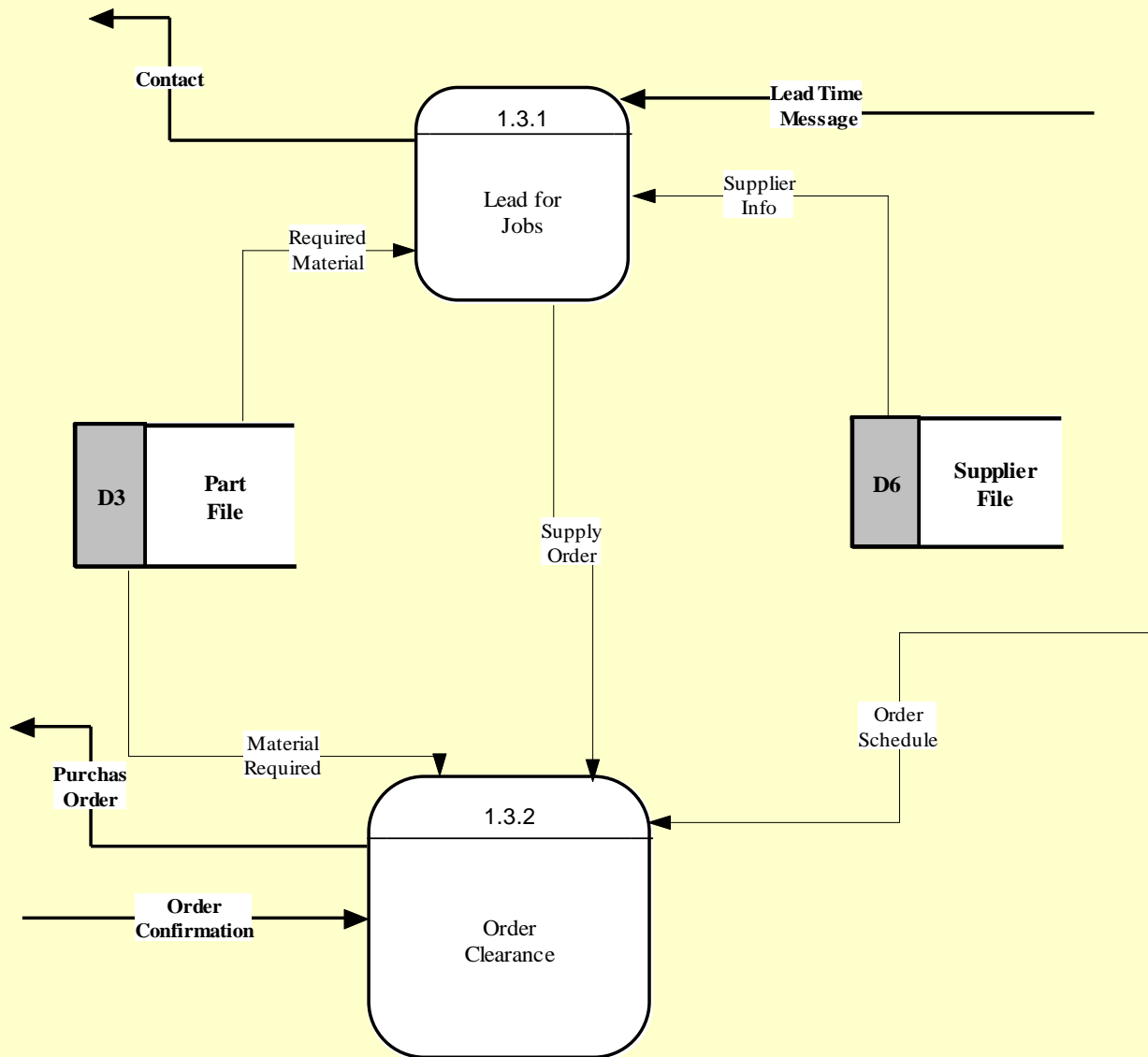

# Level 1 Diagram for 1.4 Outsourcing

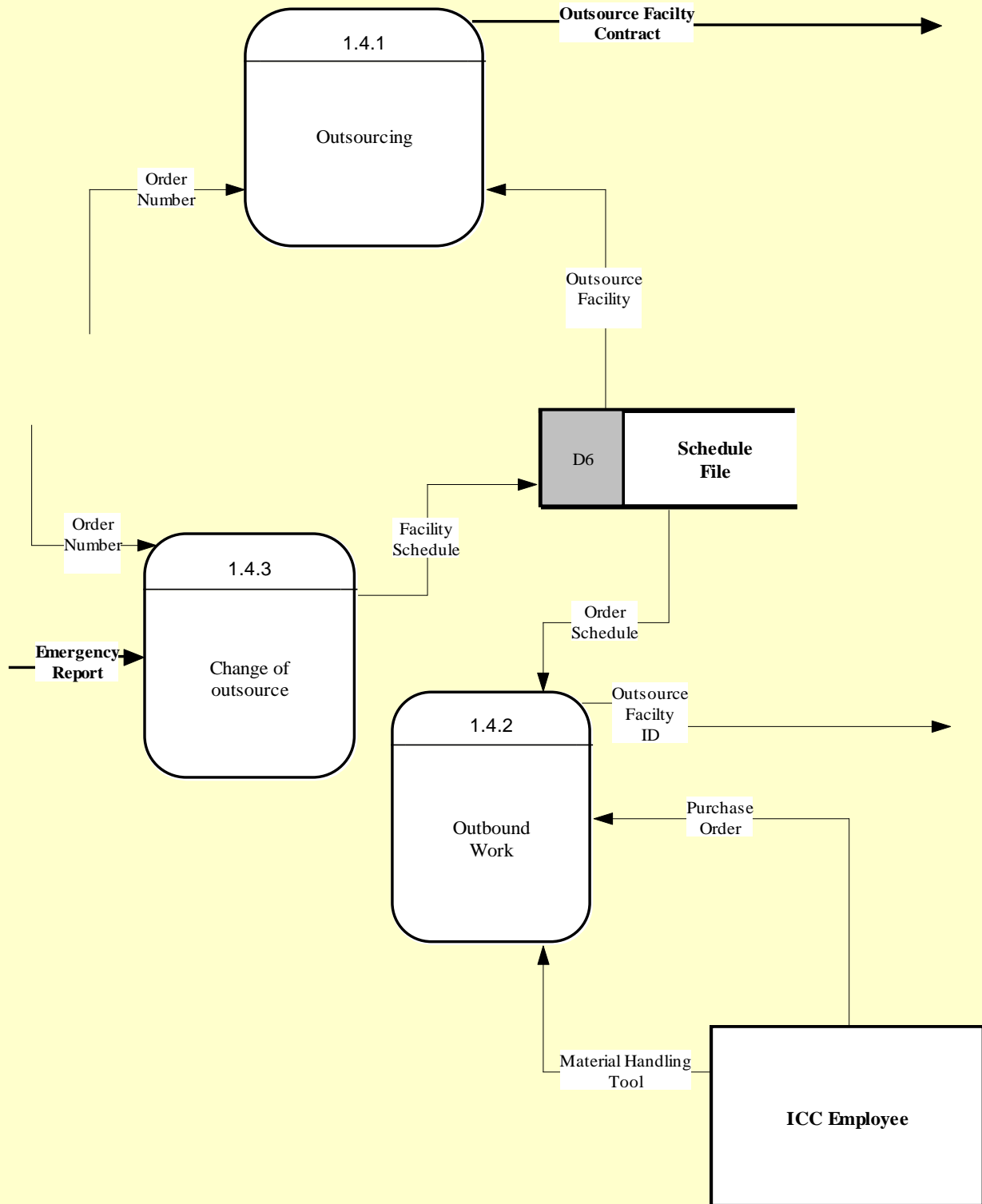

# Level 1 Diagram for 1.5 Technology Portal

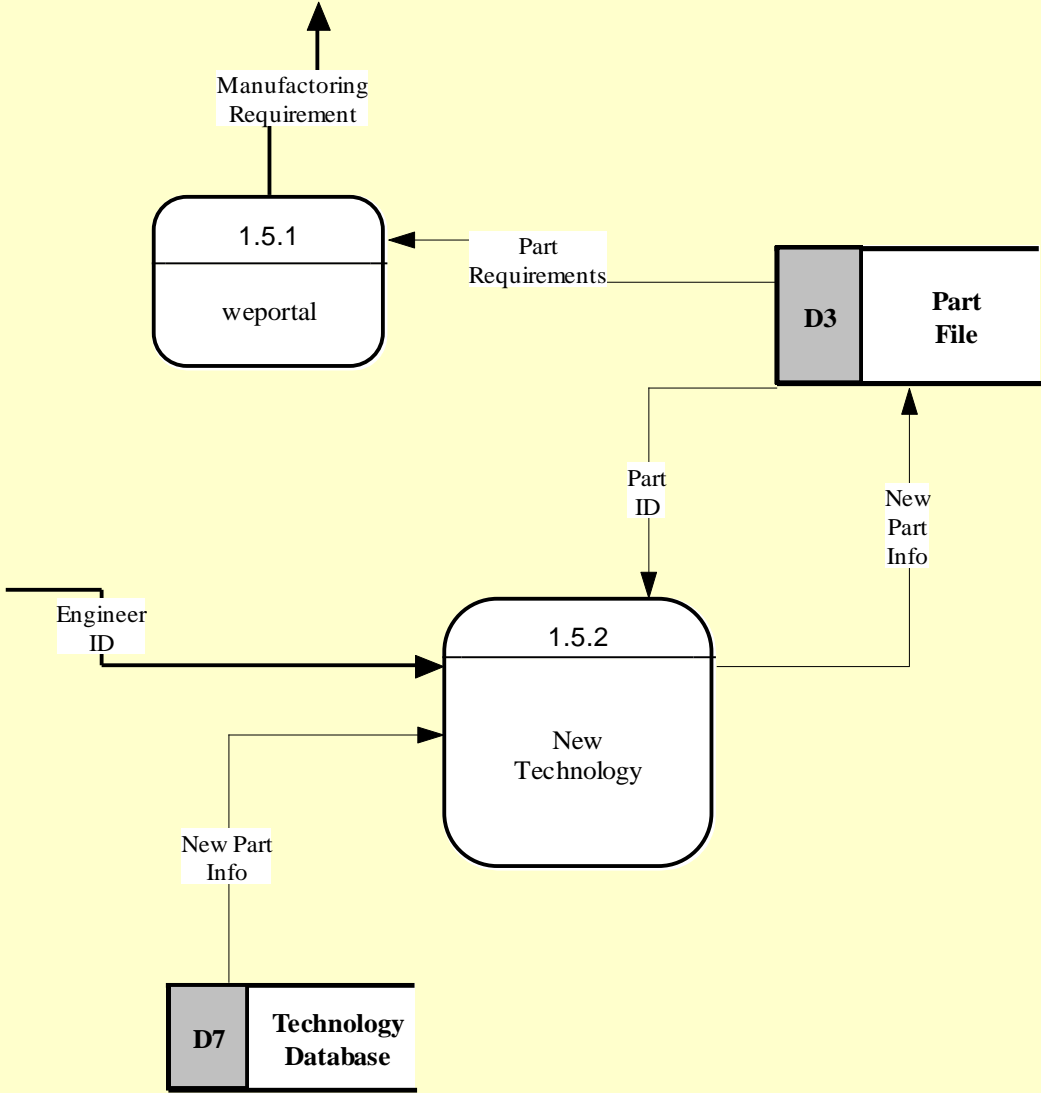



# Level 2 DFD

